

HOW TO APPLY STENCILS

IMPORTANT! • Don't overload the brush or roller with paint • Use a sealant to protect the surface

YOU WILL NEED

- Stencil template(s)
- Primer (for use indoors)
- Paint for base coat (use special outdoor/masonry paint for outdoor application)
- Paint for accent colour(s) (latex, acrylic or chalk for indoors, outdoor/masonry paint for outdoors)
- CLEAR water based polyurethane varnish for indoor application (eg Ronseal diamond hard clear floor varnish) or patio & paving seal for outdoor application (eg Thompsons clear One Coat)
- Paint brush / foam roller for base coat application
- Stencil brush / small, dense foam roller for stencil application
- Fine paint brush for touching up
- Masking tape
- Paint tray or container
- White spirit/turps to clean brushes/roller
- Paper towels

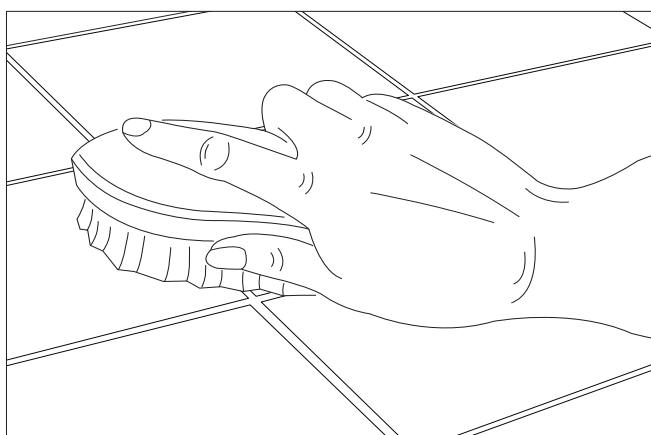
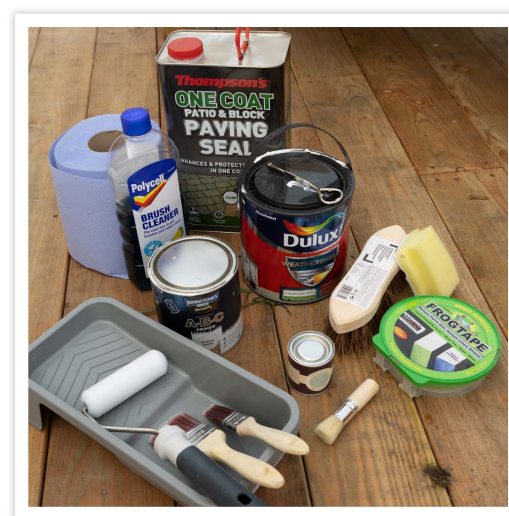

1. The surface you're stenciling needs to be fully prepped, so ensure it is completely clean and dry before you start applying paint. Patios and paths need to be jet washed to remove any dirt and debris. Indoor flooring needs a coat of primer to create a nice even base for painting.

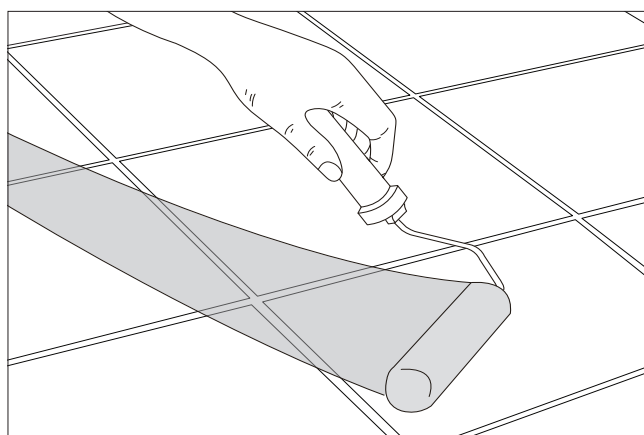

2. Use a roller to apply your base coat(s). This will form the background colour of your pattern. Your accent colour(s) will be applied over the top. Leave the paint to dry fully (in accordance with the manufacturer's guidelines – this could be up to 24 hours)

HOW TO APPLY STENCILS



3. Starting from the furthest point in the room or patio, tape the stencil into place using masking tape. It's very important that the stencil doesn't move around when painting. Apply a small amount of paint to your brush or roller (it's surprising how little paint you need – too much can cause bleeding to occur so do a test first on some paper).

Carefully apply the paint, ensuring you cover all the cut-out areas but don't go over the edges of the stencil. If you are using a couple of accent colours, make sure you paint the correct cut-outs! Once dry, carefully remove the stencil, wipe off any excess paint, then line it up with the painted pattern ready to go again. It is important that you clean the stencil between uses, as a build up of paint in the cut-out areas will prevent a neat finish.

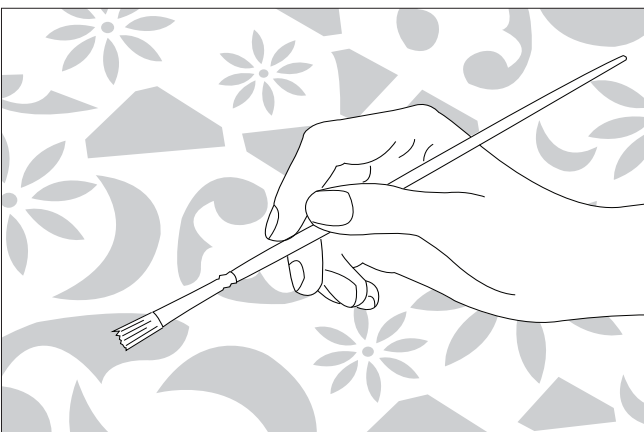

4. Once you have covered the whole area, check your work and if necessary, use a fine paint brush to touch up any bleeds or jagged lines. Leave to dry thoroughly.

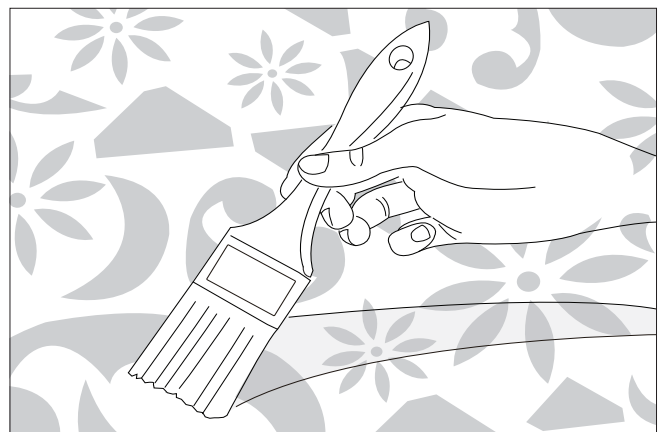

5. It's time for the crucial step of sealing the surface to protect all your hard work. For indoor flooring apply a couple of coats of good quality **CLEAR** water based polyurethane varnish. For outdoor patios and paths use patio & paving seal for protection. Leave to dry between coats and follow the manufacturer's instructions for best results.